

| DIMENSIONAL DATA | | | | | | | | | | | | | | |
|------------------|---------|--------|---------|----------|--------------|--------|---------------|---------|-------|--------|---------|------------------|--------|-----|
| MODEL NO | CABINET | | | HOOD DIM | DUCT OPENING | | DUCT LOCATION | | | | RAILING | ELECTRIC SERVICE | WEIGHT | |
| | A | B | C | D | E | F | G | H | J | K | L | M | NET | OPR |
| ARS-030 | 48 | 42 | 37-9/16 | 21-3/8 | 21-1/2 | 26-1/2 | 10 | 11-7/8 | 5-3/8 | 4-5/16 | 39-3/4 | 27-9/16 | 390 | 390 |
| ARS-070 | 48 | 48-1/4 | 55-1/16 | 28-5/16 | 30-1/2 | 26-1/2 | 14 | 18-1/16 | 5-3/8 | 4-1/4 | 46 | 27-9/16 | 540 | 540 |
| ARS-100 | 62 | 60-1/4 | 60-5/16 | 29-7/8 | 44-1/2 | 32-1/2 | 16 | 13-9/16 | 5-3/8 | 4-3/8 | 58 | 51-3/4 | 965 | 965 |

SITE PREPARATION & UNIT LOCATION

- “ SERVICE CLEARANCES SHALL BE THE SAME WIDTH AS THE UNIT ITSELF, EXCEPT THE SUPPLY END WHICH IS A MINIMUM OF 18”.
- “ AVOID OVERHEAD POWER LINES, OR OTHER UTILITY ACCESS TO PREVENT CONTACT OR DAMAGE.
- “ SEE IOM FOR DETAILED SITE PREPARATIONS AND INSTALLATION.

| FILTER OPTIONS | | | | | | |
|----------------|---------------|-----------|--------------------|------------------|-----------|-------------------|
| MODEL NO | INLET FILTERS | | | 2" FINAL FILTERS | | |
| | QTY | SIZE | TYPE | QTY | SIZE | TYPE |
| ARS-30 | 4 | 16" X 20" | 1" ALUM 2" ALUM | 4 | 16" X 20" | MERV 8 MERV 13 |
| ARS-70 | 4 | 24" X 24" | 1" ALUM 2" ALUM | 6 | 16" X 24" | MERV 8 MERV 13 |
| ARS-100 | 6 | 20" X 25" | 1" ALUM 2" ALUM | 6 | 20" X 25" | MERV 8 MERV 13 |

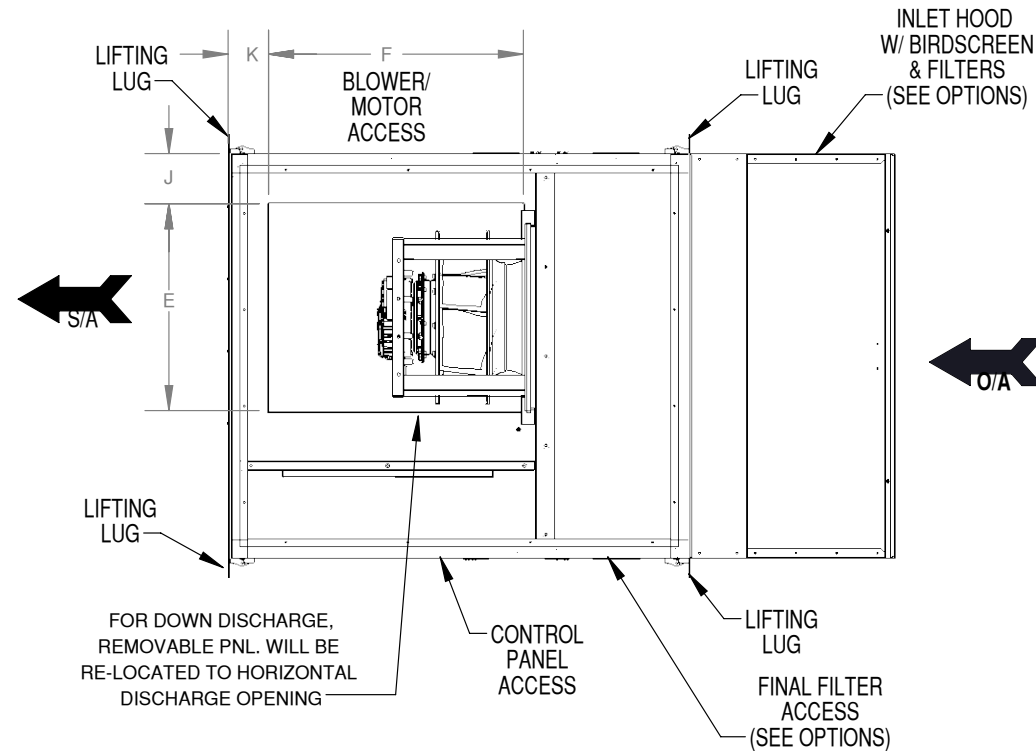

DETAIL A
RAILING PROFILE

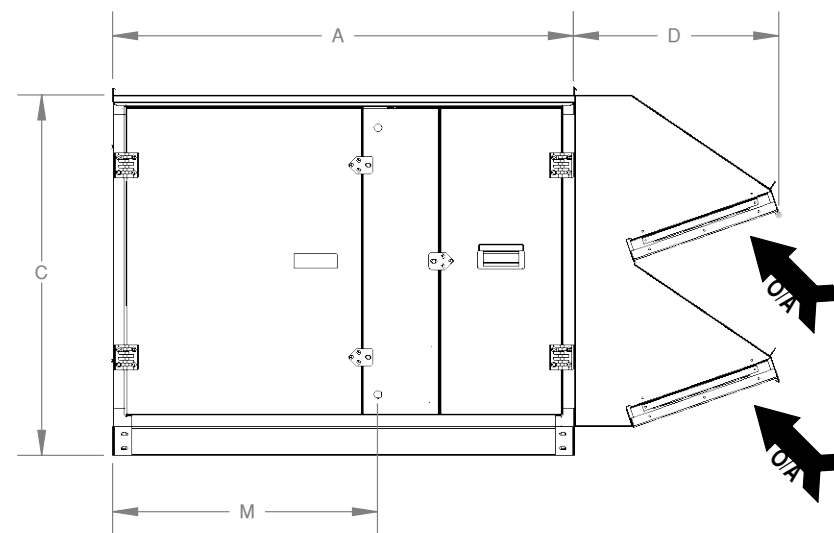
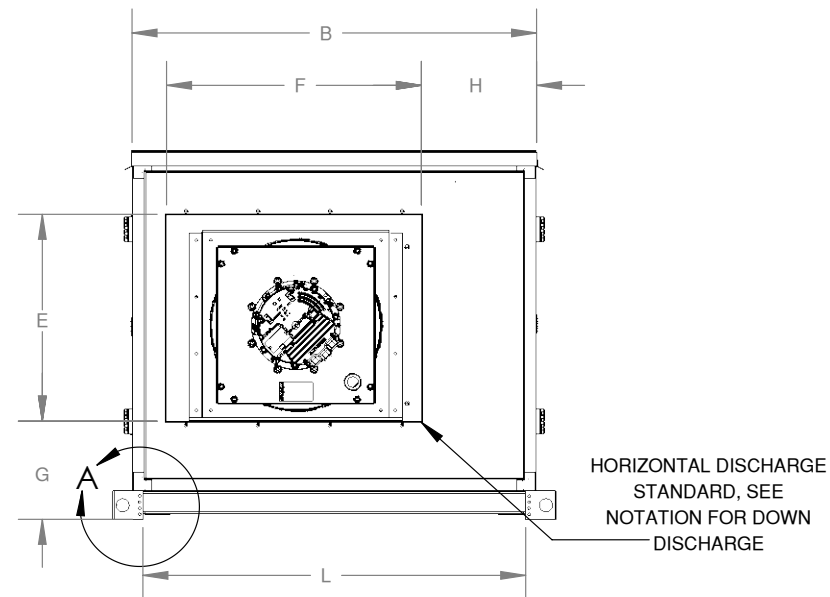
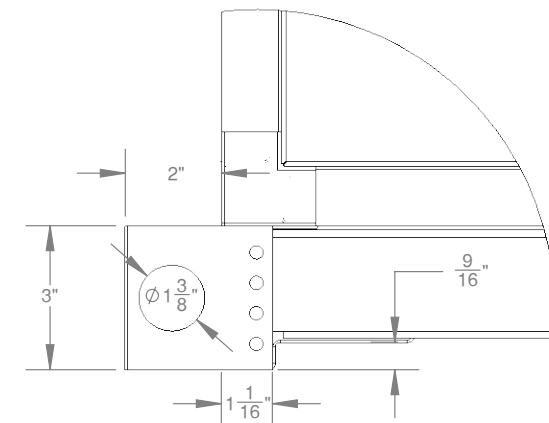

| | | | | |
|------|-------------|-----------|----|------|
| F | | 6/26/2017 | | |
| E | | | | |
| D | | | | |
| C | | | | |
| B | | | | |
| A | | | | |
| REV. | DESCRIPTION | DATE | BY | ECN# |

ARES RESERVES THE RIGHT TO CHANGE SPECIFICATIONS AND PRODUCT DESIGN WITHOUT NOTICE. SUCH REVISIONS DO NOT ENTITLE THE BUYER TO CORRESPONDING CHANGES, IMPROVEMENTS, ADDITIONS OR REPLACEMENTS FOR PREVIOUSLY PURCHASED EQUIPMENT.

| | | |
|---------------|------|------------|
| SUBMITTAL NO. | | |
| APF1XXCX | | |
| SCALE: 1:24 | NAME | DATE |
| DRAWN BY: DW | | 01/04/2017 |



